

DELUXE 30-INCH CHARCOAL GRILL

PARRILLA DE CARBÓN DE LUJO DE 30 PULGADAS

GRIL DE LUXE AU CHARBON DE BOIS DE 30 POUCES

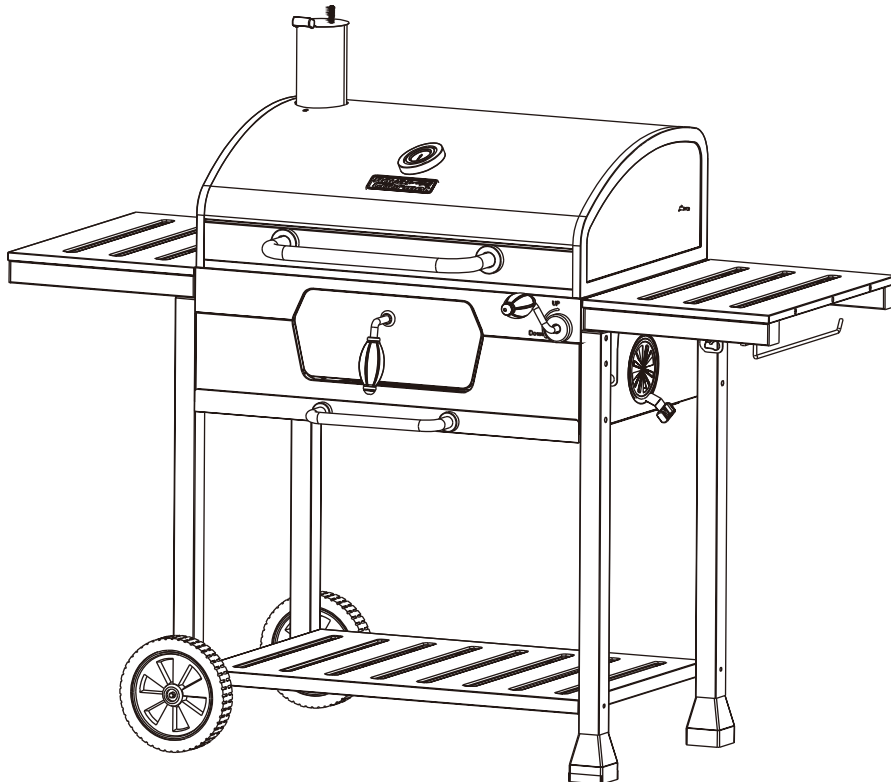

FOR YOUR SAFETY! | ¡PARA SU SEGURIDAD! | POUR VOTRE SÉCURITÉ!

Use outdoors only!
Read the instructions before
assembling and using the appliance.

¡Solo usa al aire libre!
Lea las instrucciones antes
de montar y utilizar el aparato.

Utilisez uniquement à l'extérieur!
Lisez les instructions avant
d'assembler et d'utiliser l'appareil.

CONTACT US FIRST! | ¡PÓNGASE EN CONTACTO CON NOSOTROS PRIMERO! | CONTACTEZ-NOUS D'ABORD!

If you have any questions that are
not addressed, please contact us first.

Si tiene alguna pregunta que no se
aborde en este Manual del Usuario,
póngase en contacto con nosotros primero.

Si vous avez des questions qui ne
sont pas traitées dans ce manuel de
l'utilisateur, contactez-nous d'abord.



Customer Service / Servicio al Cliente / Service de Clientèle

 1-800-618-6798









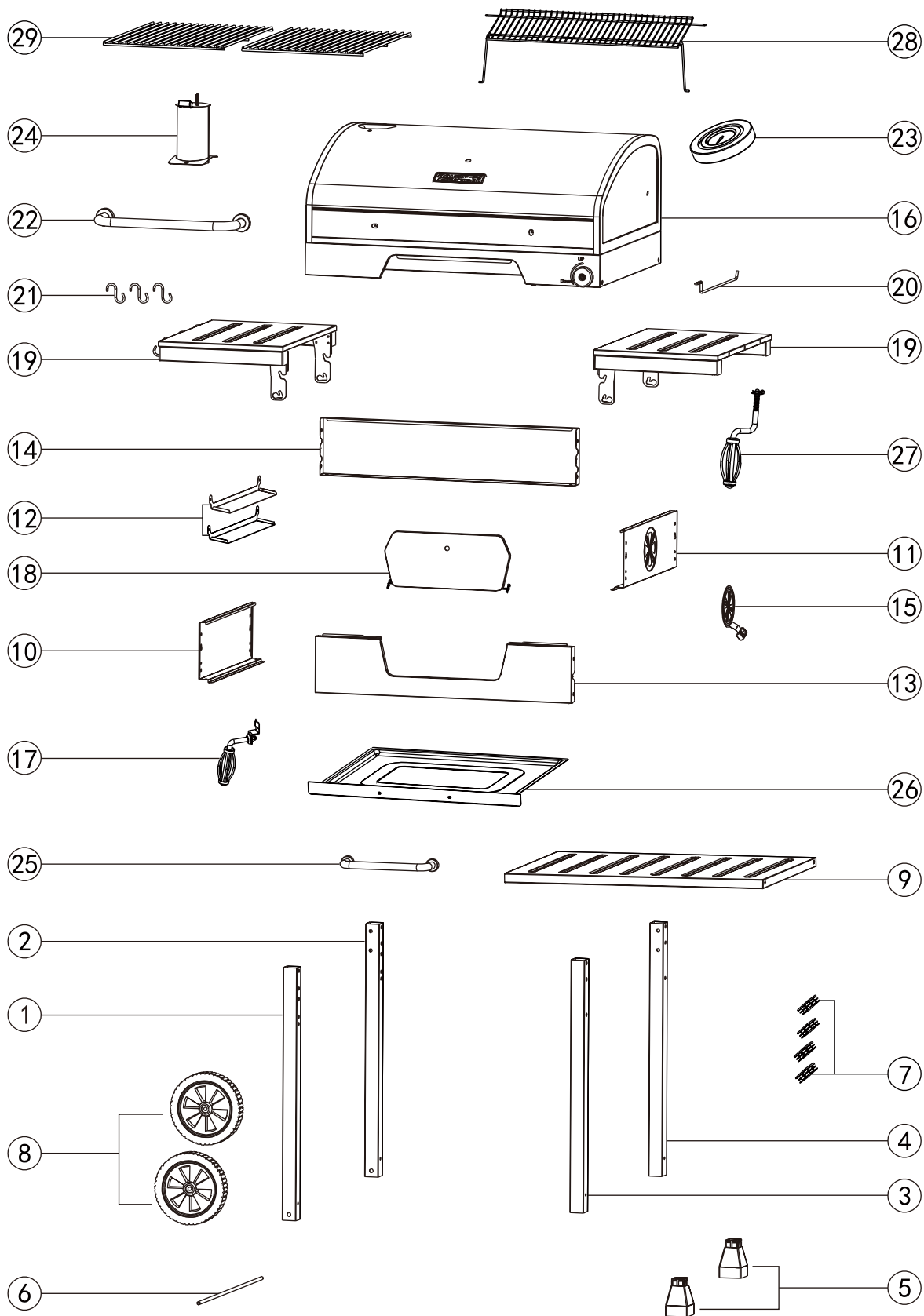

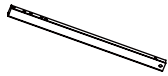

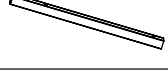



 service@royalgourmetusa.com



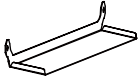







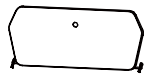

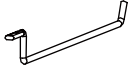
Learn more at / Obtener más información en / Pour en savoir plus:









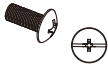

www.royalgourmetcorp.com





No.	#	QYT / CANT. / QTÉ	Description / Descripción / Description	Image / Imagen / Image
1	Z-CD203034	1	Left front leg Pata delantera izquierda Pied avant gauche	
2	Z-CD203033	1	Left back leg Pata trasera izquierda Pied arrière gauche	
3	Z-CD203032	1	Right front leg Pata delantera derecha Pied avant droit	
4	Z-CD203031	1	Right back leg Pata trasera derecha Pied arrière droit	
5	W-CD203014	2	Leg base Pata base Base de pied	
6	W-CD203016	1	Wheel axle Eje de rueda Essieu de roue	
7	W-CD203015	4	Leg plug Tapone de tubería Bouchons de jambe	
8	W-R33005	2	Wheel Rueda Roue	
9	Z-CD203028	1	Bottom shelf Estante inferior Étagère inférieure	
10	Z-CD203022	1	Left panel Panel izquierdo Panneau gauche	
11	Z-CD203021	1	Right panel Panel derecho Panneau droit	
12	Z-CD203035	2	Grease deflector Deflector de grasa Déflecteur de graisse	
13	Z-CD203020	1	Front panel Panel frontal Panneau avant	
14	Z-CD203023	1	Rear panel Panel trasero Panneau arrière	
15	Z-ZH2302030+ W-ZH300101	1	Side damper Regulador de tiro Amortisseur	
16		1	Main body Cuerpo principal Corps principal	
17	W-R3003	1	Door handle Manija de puerta Poignée de porte	

No.	#	QYT / CANT. / QTÉ	Description / Descripción / Description	Image / Imagen / Image
18	Z-CD203038	1	Charcoal access door Puerta de acceso del carbón Porte d'accès au charbon	
19	ZH-CD203003	2	Side table Mesa lateral Table d'appoint	
20	W-CD203010	1	Paper towel holder Portarrollos de papel Porte-serviettes en papier	
21	W-CC115WT008	3	"S" hook Gancho en forma de S Crochet en «S»	
22	W-DXL12014	1	Lid handle Manija de la tapa Poignée du couvercle	
23	WJ300-RGC	1	Thermometer Termómetro Thermomètre	
24	ZH-CD203005	1	Stack Chimenea Cheminée	
25	BXGBS248	1	Handle for ash tray Manija de la cenicero Poignée du bac à cendres	
26	Z-CD203025	1	Ash tray Cenicero Bac à cendres	
27	W-HD20T013+ W-CD203007	1	Crank handle Manivela Manivelle	
28	W-CD203017	1	Warming rack Rejilla para calentar Grille de réchauffement	
29	W-CD203018	2	Cooking grate Rejilla para asar Grille de cuisson	

Key / Clave / Réf.	Description / Descripción / Description	QTY / CANT. / QTÉ	Image / Imagen / Image
A	M6x60	16	
B	M6x12	12	
C	Split pin / Washer Pasador doble / Arandela Goupille fendue / Rondelle	5 / 1	
D	M4x10	6	
E	M6x40	2	
F	Shoulder bolt Perno de hombro Boulon à épaulement	8	
G	M6	2	
H	Washer Arandela Rondelle	2	
I	Spring washer Arandela elástica Rondelle élastique	1	
J	M5x12	1	
K	M5	1	

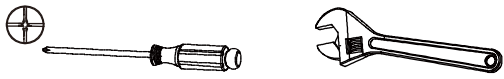
TOOLS REQUIRED / HERRAMIENTAS REQUERIDAS / OUTILS REQUIS		
Description / Descripción / Description		Image / Imagen / Image
Phillips screwdriver Destornillador phillips Tournevis phillips	Wrench Llave Clé	

Before beginning assembly, make sure all parts are present. If any parts are missing or damaged, do not attempt to assemble the products. Contact customer service for replacement parts via telephone or email.

- Tools needed (not included): Phillips screwdriver and wrench
- Approximate assembly time: 50 minutes
- Note: 1. The right and left sides of the grill are designed as if you are facing the front of the grill.
2. Model shown for illustration purpose only, specific please in kind prevail.

Antes de comenzar el montaje, asegúrese de que todas las piezas estén presentes. Si falta alguna pieza o está dañada, no intente ensamblar los productos. Póngase en contacto con el servicio de atención al cliente para obtener piezas de repuesto por teléfono o correo electrónico.

- Herramienta necesaria (no incluido): Destornillador phillips y llave
- Tiempo aproximado de ensamblaje: 50 minutos
- Nota: 1. Los lados derecho e izquierdo de la parrilla están diseñados como si estuvieras frente a la parte delantera de la parrilla.
2. El modelo que se muestra es sólo para fines ilustrativos, prevalecen los específicos en especie.

Avant de commencer l'assemblage, assurez-vous que toutes les pièces sont présentes. Si des pièces sont manquantes ou endommagées, n'essayez pas d'assembler les produits. Contactez le service de clientèle pour les pièces de rechange par téléphone ou par e-mail.

- Outils nécessaires (non inclus): Tournevis phillips et clé
- Temps nécessaire pour l'assemblage: 50 minutes
- Remarque: 1. Les côtés droit et gauche du gril sont concus comme si vous faisiez face à l'avant du gril.
2. Le modèle est présenté à des fins d'illustration uniquement, spécifiques en nature prévalent.

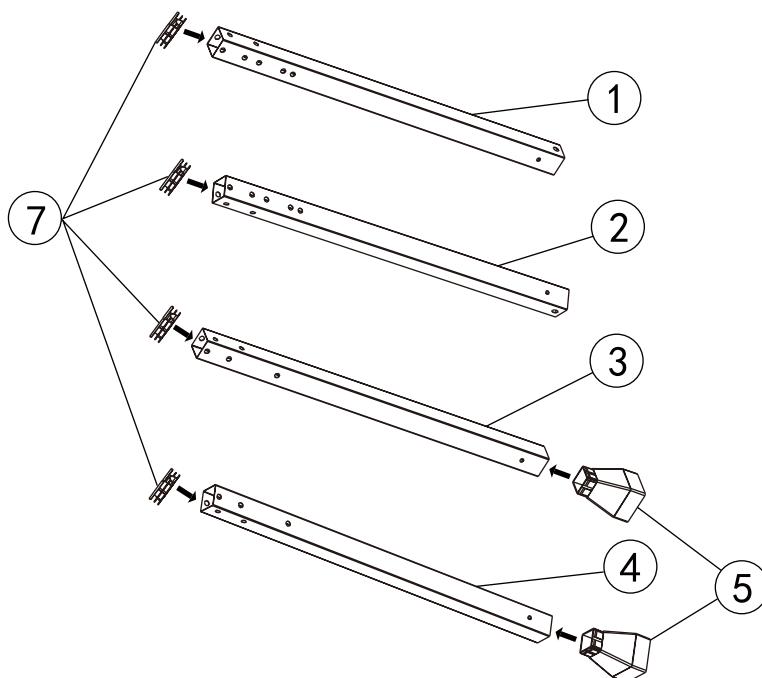

1





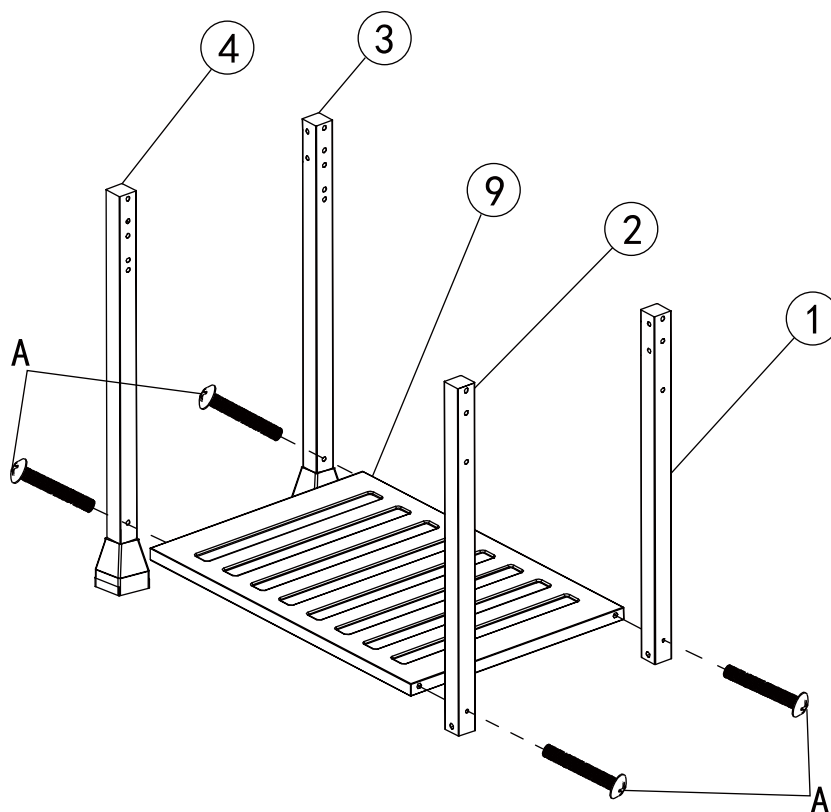

2

A		x4
---	---	----

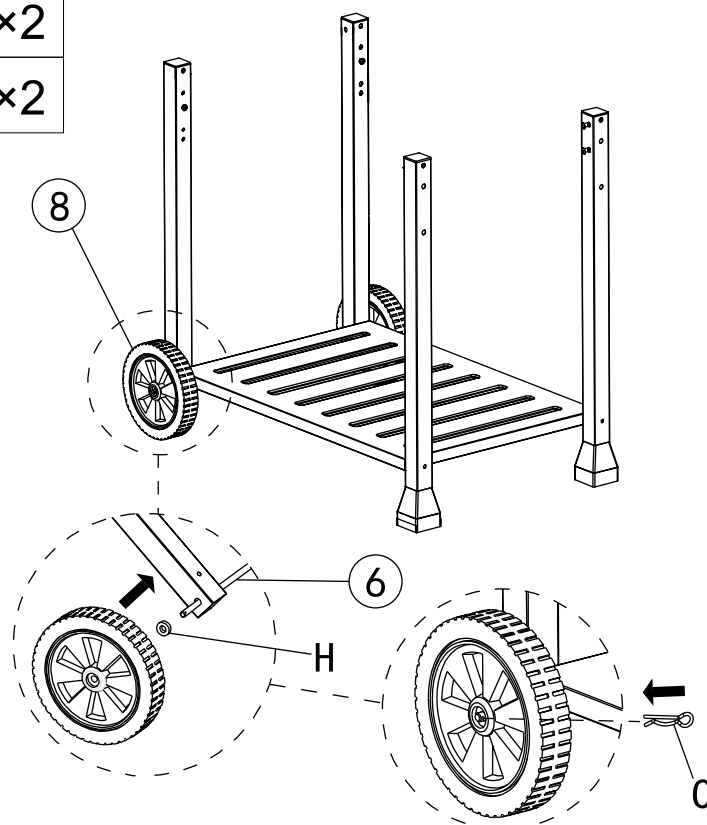

3	H		×2
	C		×2



4	I		×1
	K		×1
	J		×1

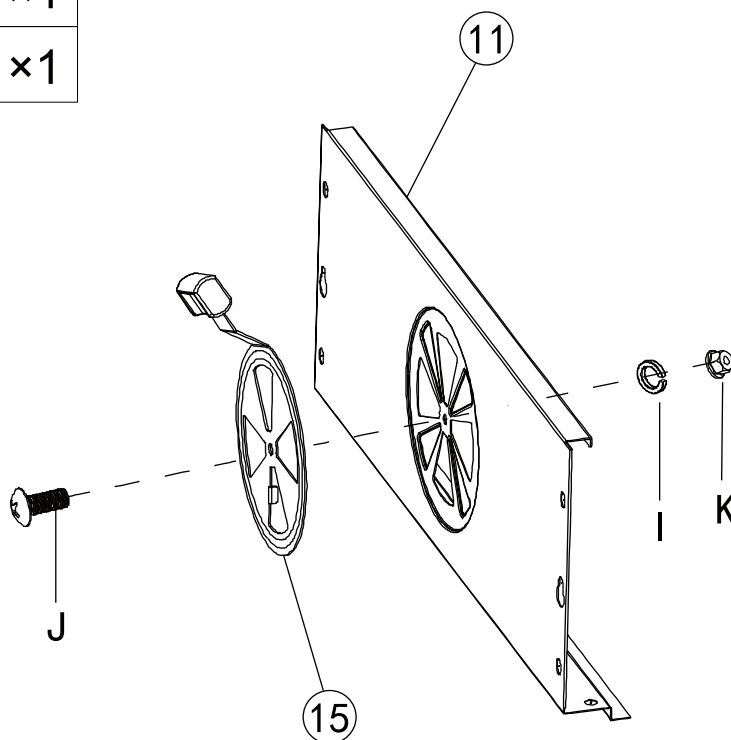

5 **B**  **×4**

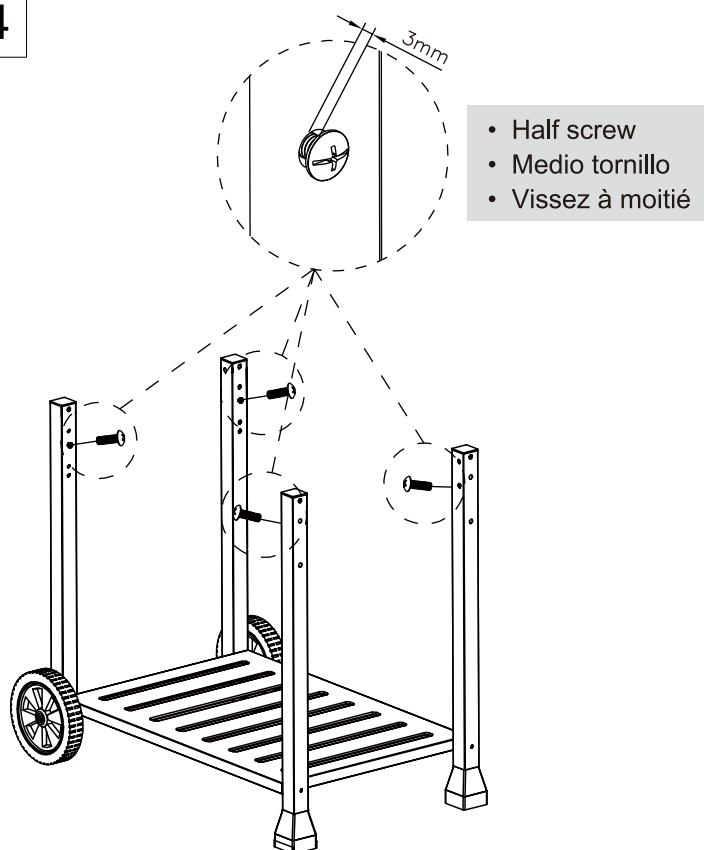

6

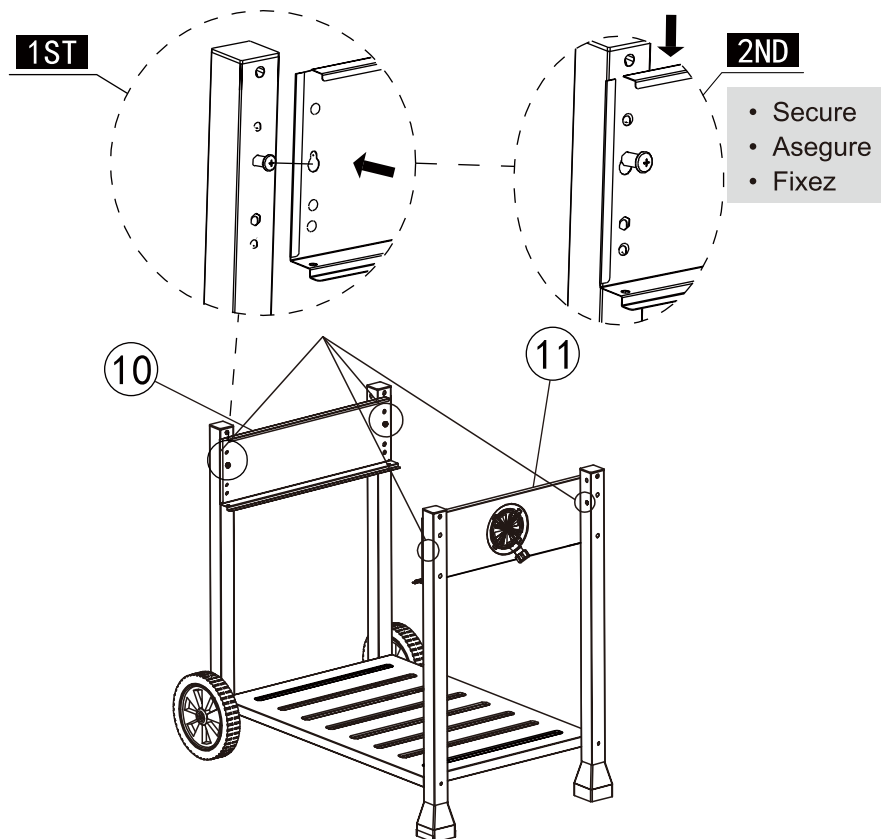

7	B		×4
---	---	---	----

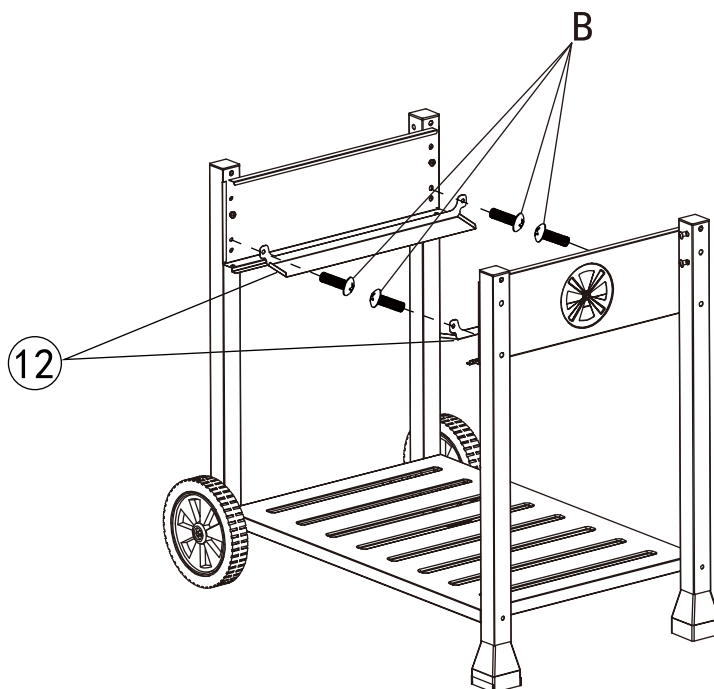

8	A		×8
---	---	---	----

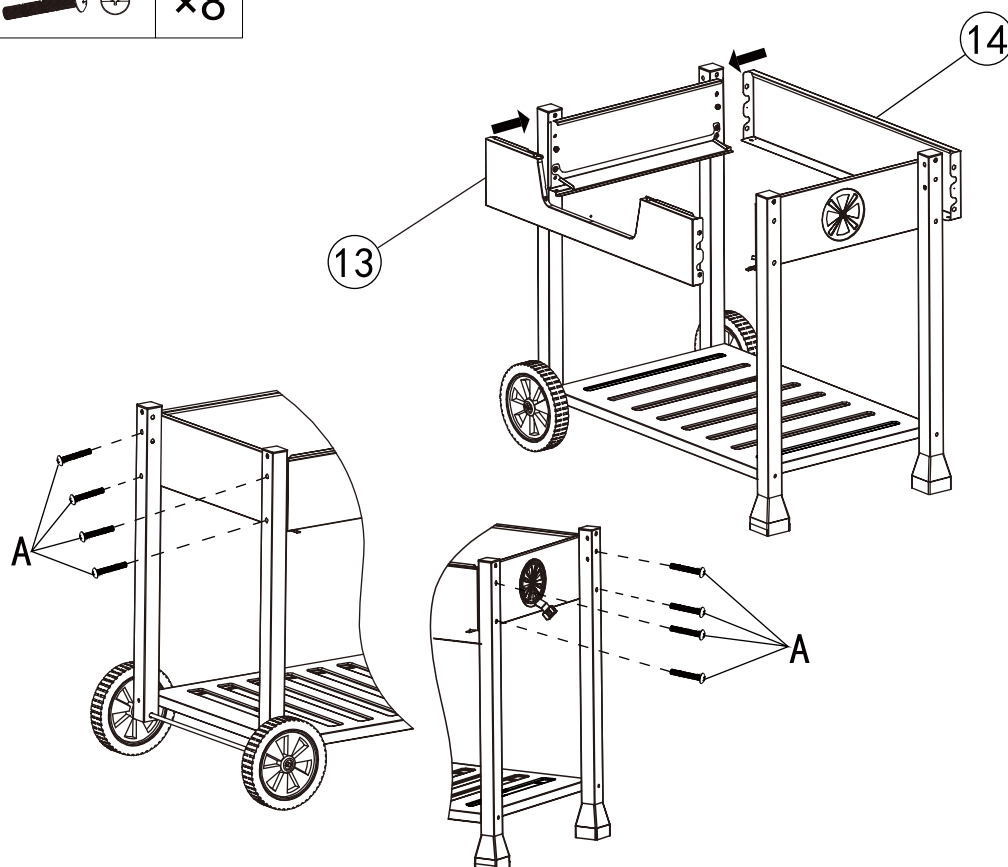

9 D  ×4

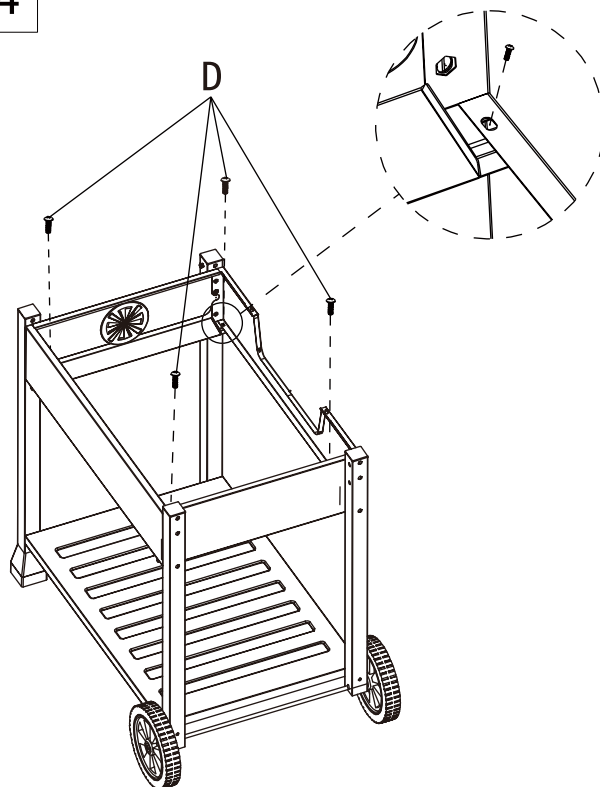

10 A  ×4



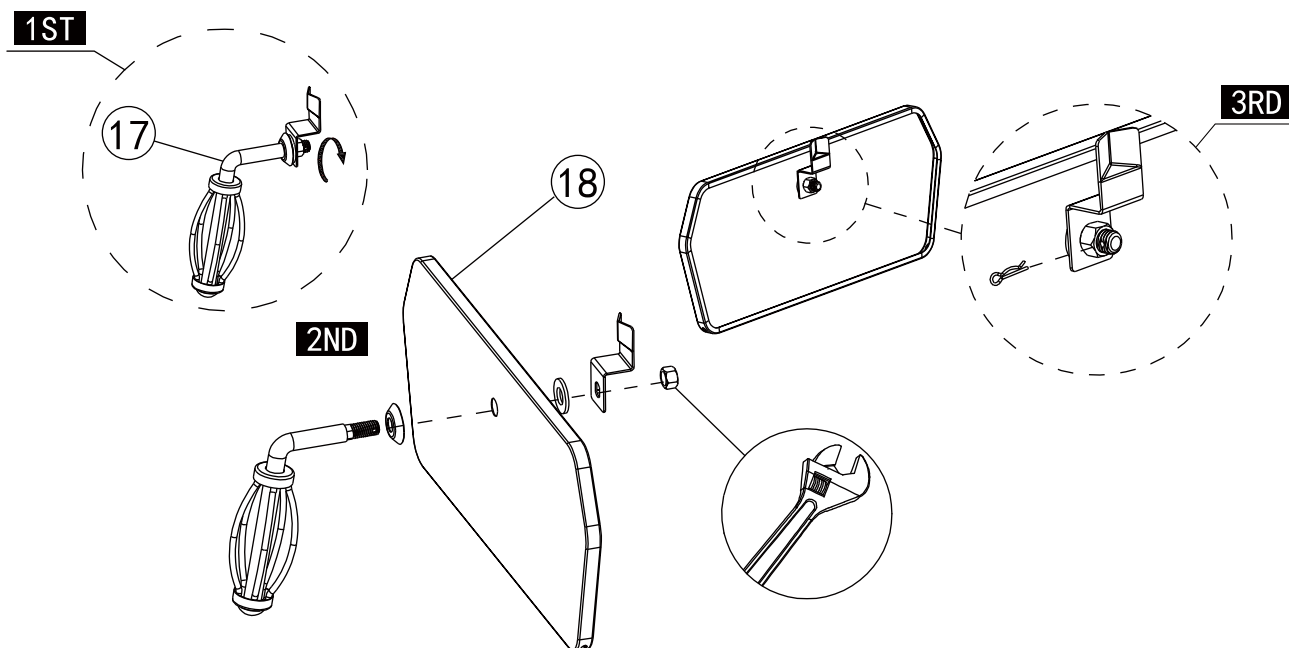

11

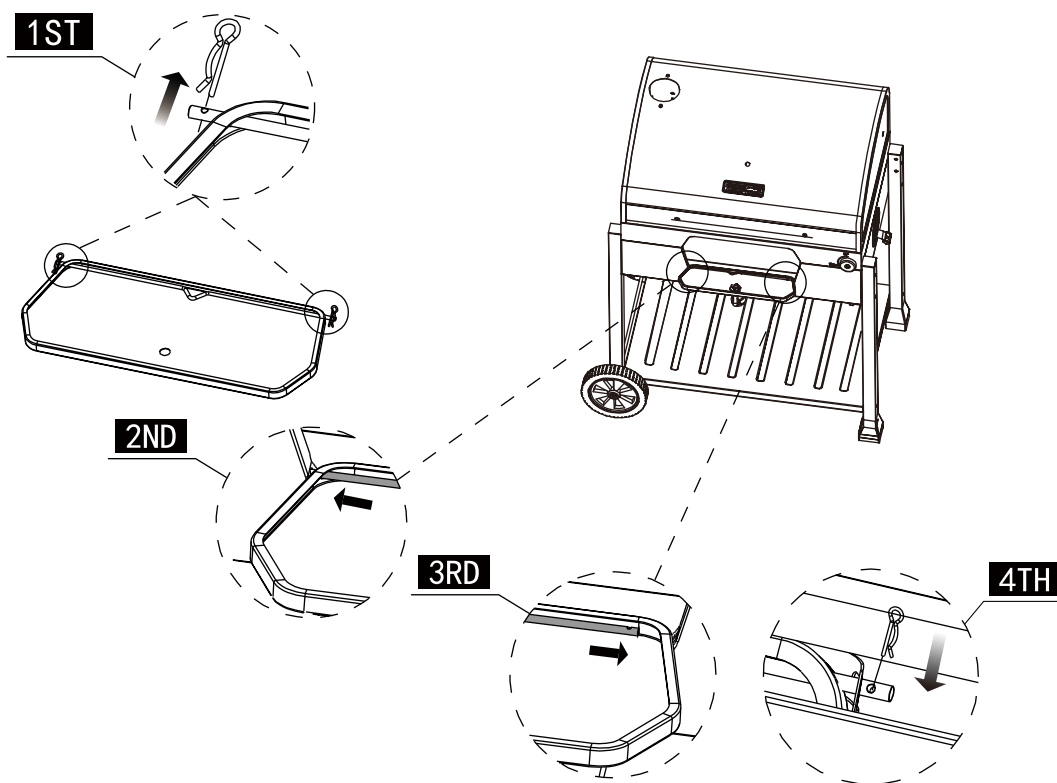

12



13	C		×3
	D		×2

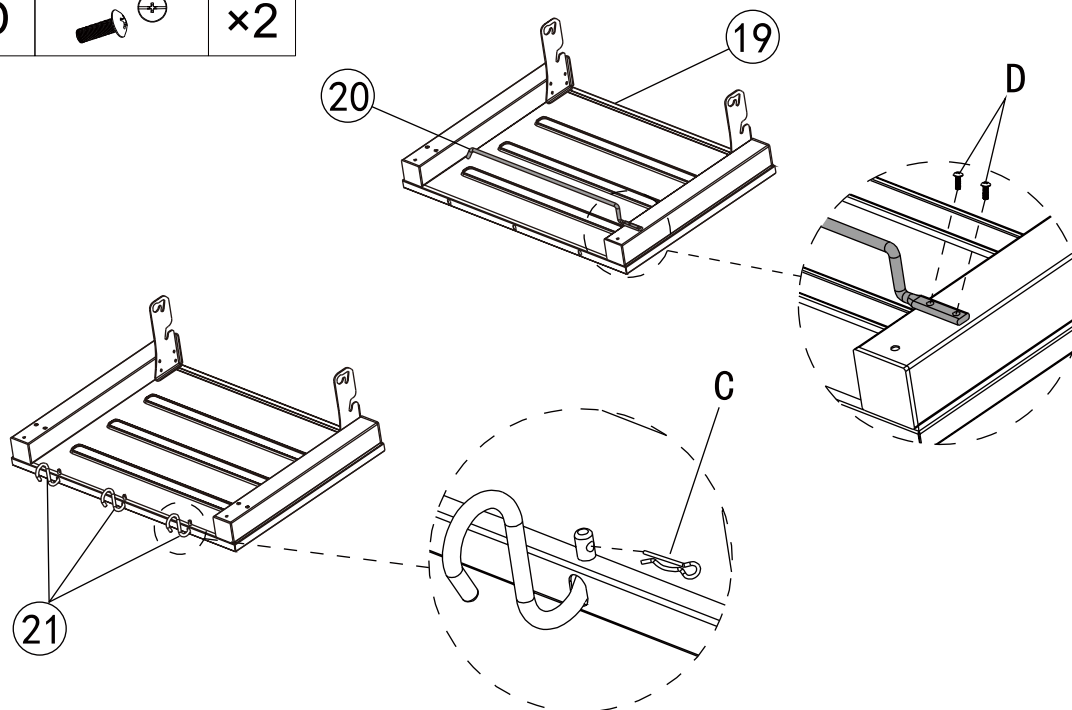

14	F		×8
----	---	---	----

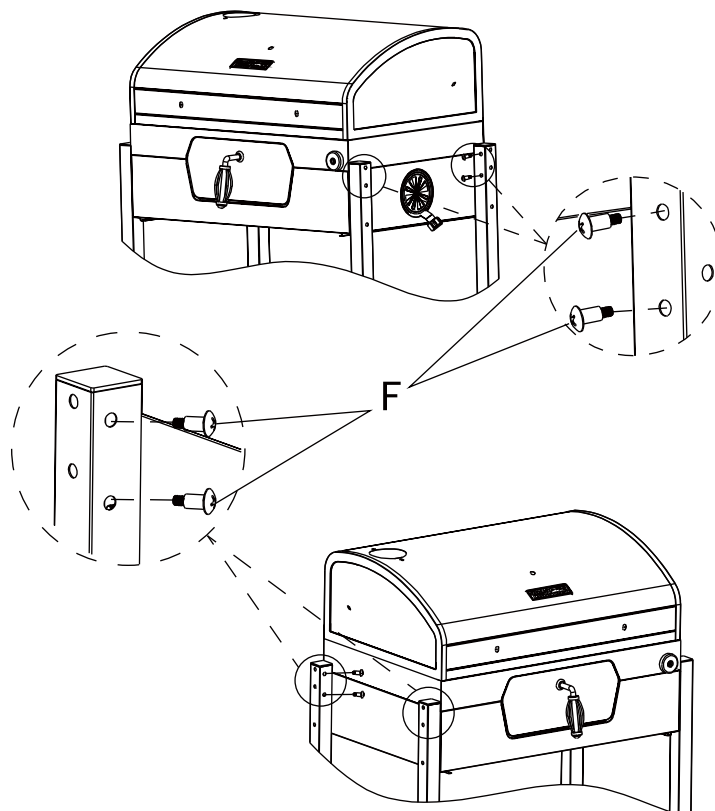

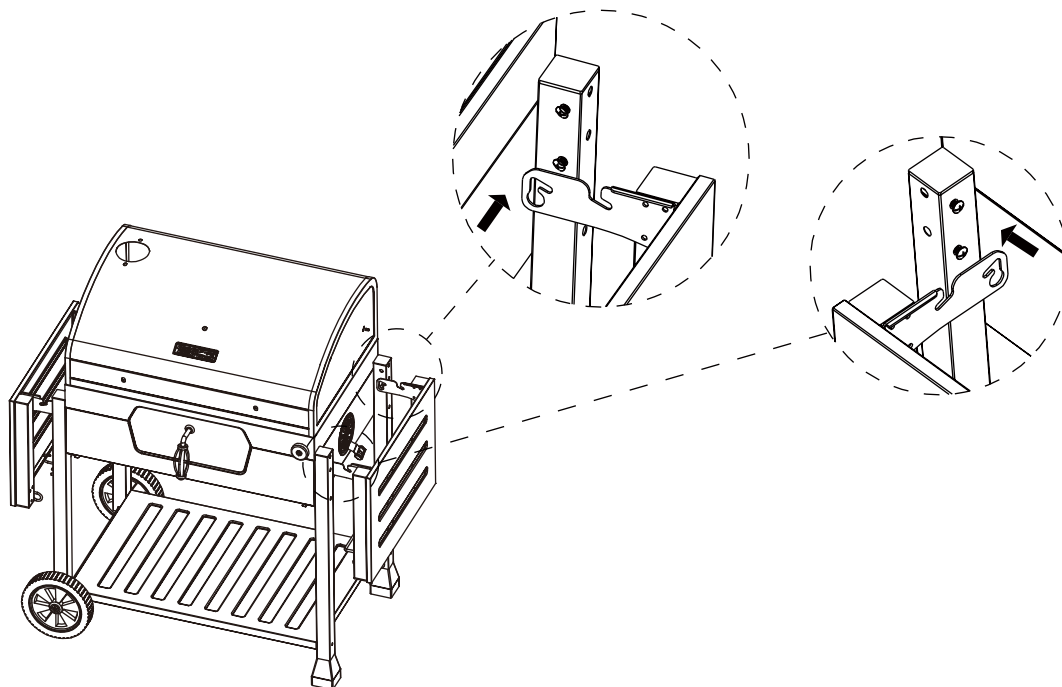

15



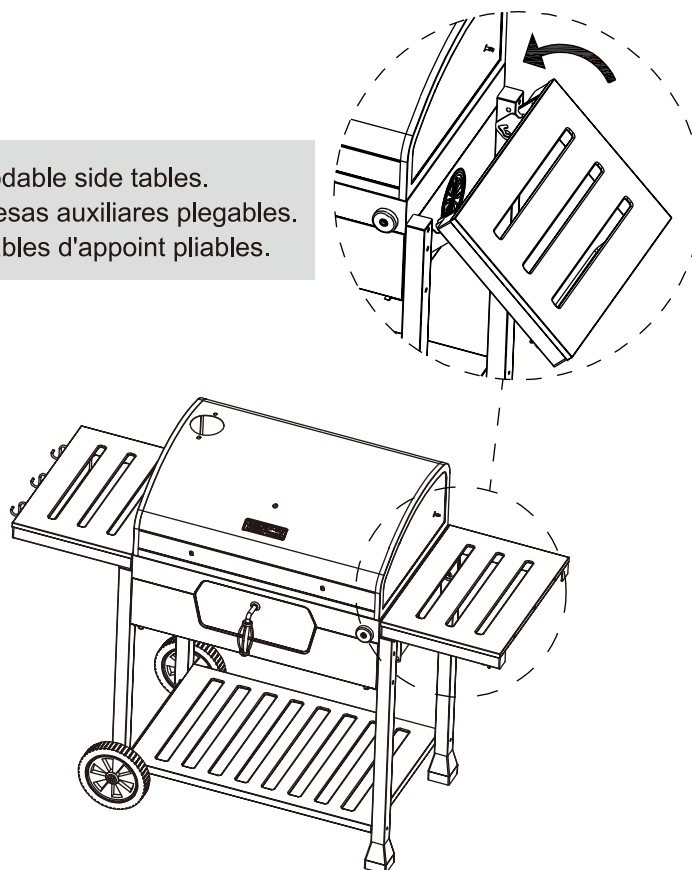

16

- Fodable side tables.
- Mesas auxiliares plegables.
- Tables d'appoint pliables.



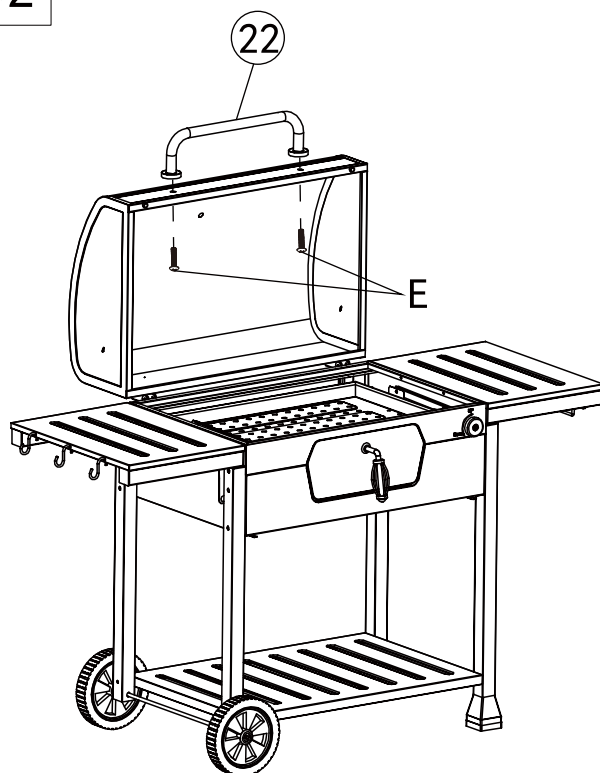

17 E  ×2

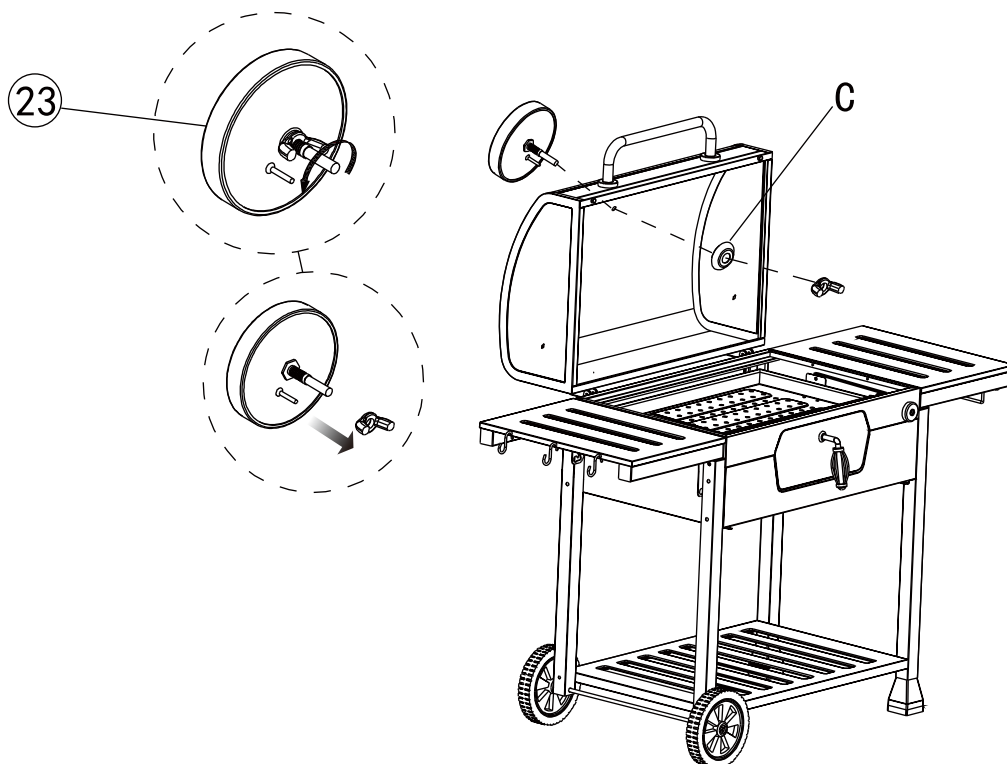

18 C  ×1



19	G		×2
	B		×2

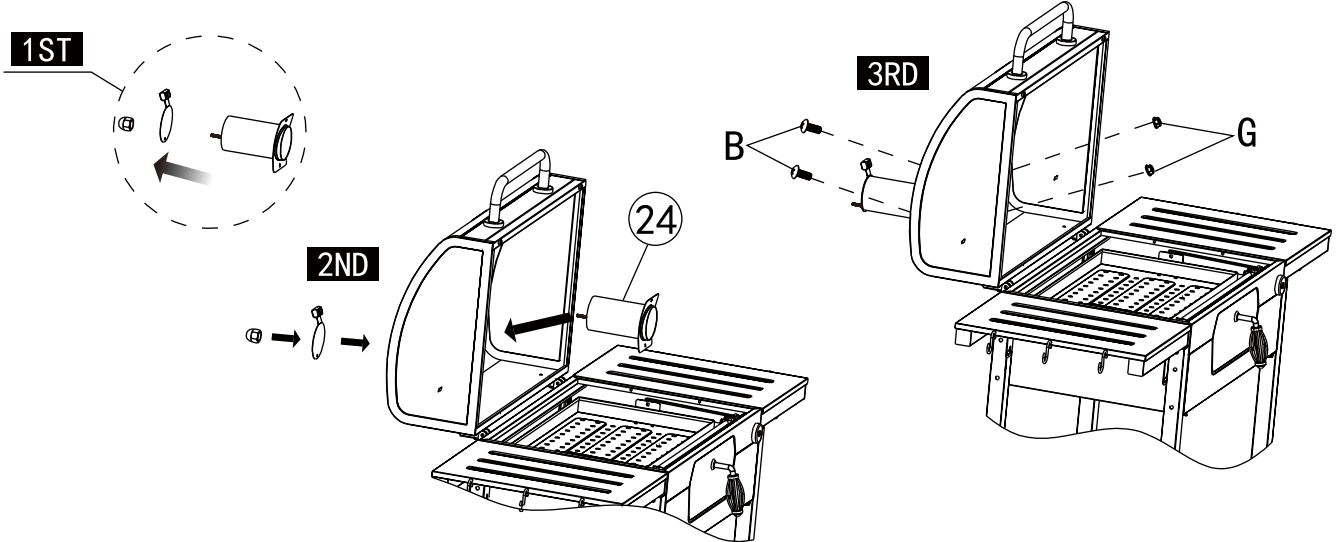

20	B		×2
----	---	---	----

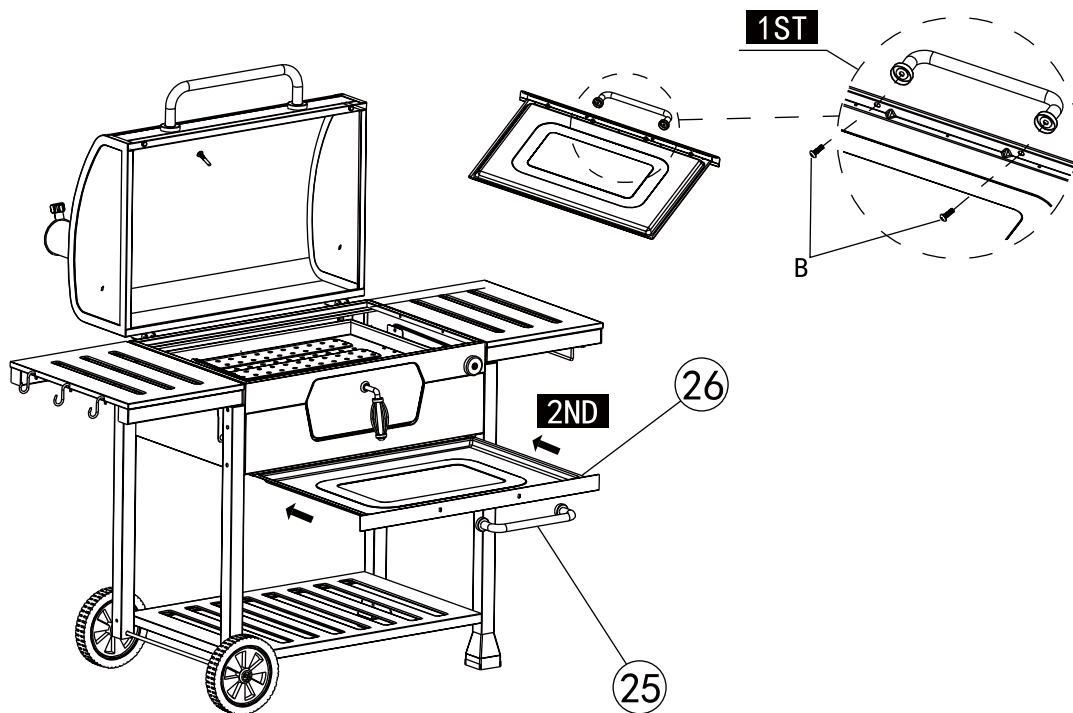

21

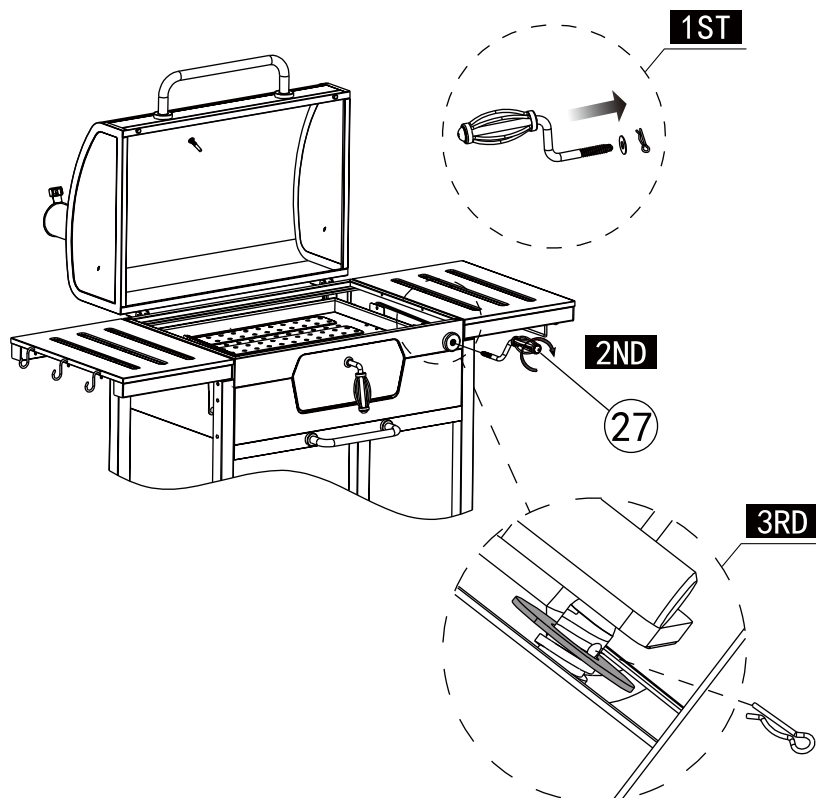

- Raise charcoal pan higher so as to secure crank.
- Levante primero la bandeja de charcoal y luego fije la manivela.
- Relevez d'abord le bac à charbon, puis fixez la manivelle.

22

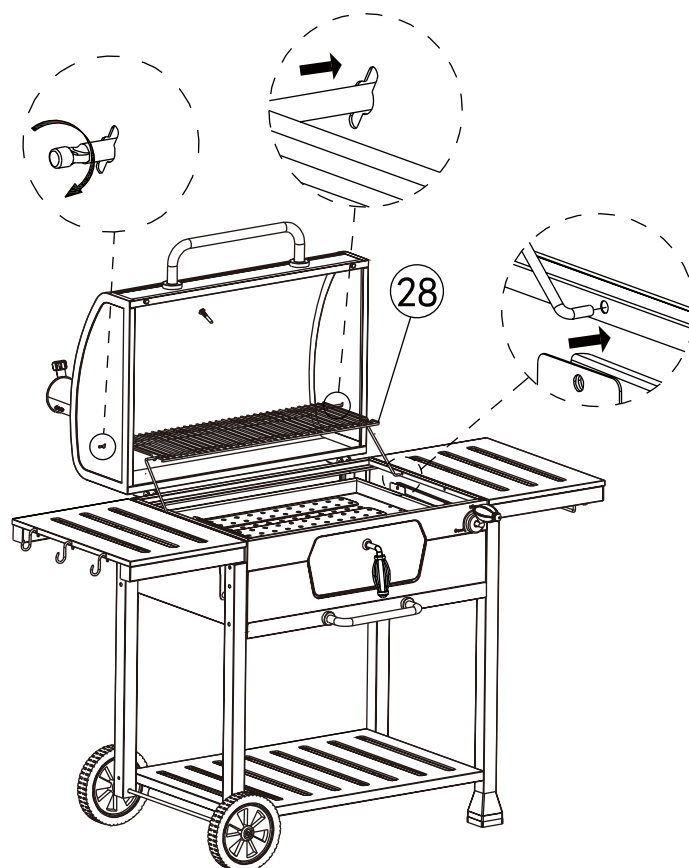

23

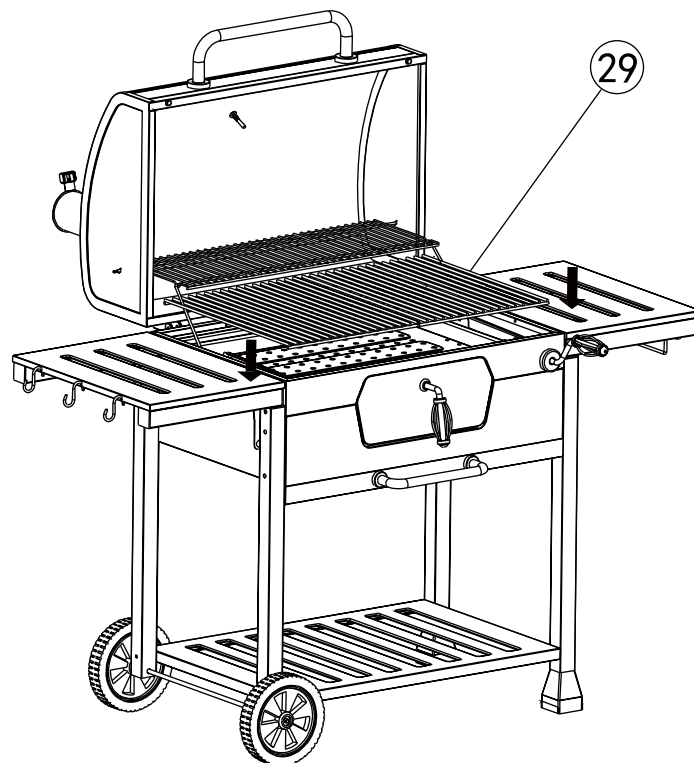

**Thank You
For Choosing Us.**

**Any Problem!
We Can Help!**

**Customer
Service**

1-800-618-6798

Monday to Friday (8:30 am - 5:30 pm EST)

service@royalgourmetusa.com